

AEROGAIN-BASE 1.2

High power pulsed ytterbium fiber amplifier OEM module

DECEMBER 25

USER GUIDE

This document contains critical information on how the aeroGAIN-Base (AGB) 1.2 unit should be handled, installed and used. It is important that this document is read and understood before the aeroGAIN-Base unit is being used.

You can find additional resources on the NKT Photonics website, where a datasheet, specifications, mechanical drawings, and 3D model (.STEP) files for the module, tooling plate, and mounting handle tool can be downloaded.

This instruction covers the AGB-1.2 which is designed for 1030 nm operation. Compared to previous versions, the AGB-1.2 (C331-205-18x) has fiber and end-cap housing in the table plane and is reduced in size.

Please refer to the datasheet, technical drawing, and provided 3D model (.STEP) files of the module for detailed dimensions. Throughout this document, pictures and drawings of 1.2 are included.

DO NOT remove the module from the tooling plate unless the end-cap adapter and baseplate are fixed to each other

Use an AGB Mounting handle tool, as described in the section: "To remove the module from the tooling plate"

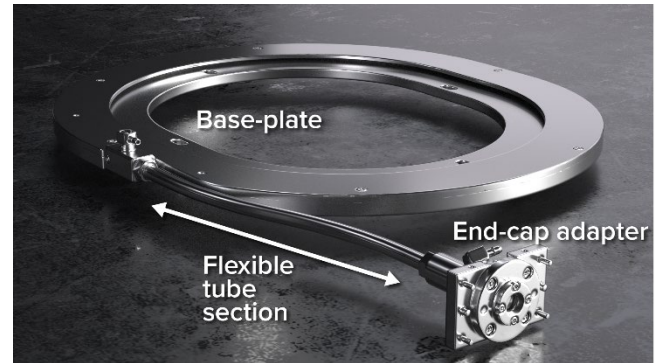

S-bend Tube Section

To avoid stress on the fiber during temperature cycling, the aeroGAIN-BASE-1.2 module is designed with an S-bend tube section which is slightly flexible. The end-cap housing and the fiber spool must always be kept in fixed positions relative to each other to avoid stretching the fiber in the S-bend tube section. This might damage the fiber permanently and may cause catastrophic module failure.

Therefore, modules are shipped on special tooling

DO NOT handle the unit using the S-bend tube as handle!

plates. These plates can also be used as mounts during testing in the lab. NEVER loosen the 4 "base screws" without a fixture being attached. See additional details in the section titled "To remove the module from the tooling plate".

When mounted on a tooling plate, use this plate for handling.

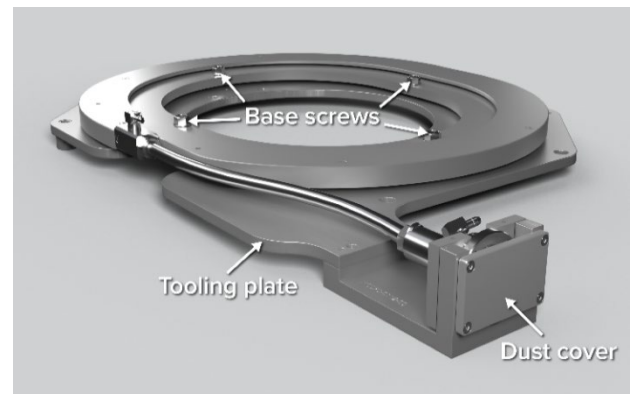

A dust cover plate protects the end-cap surface. This cover plate needs to be removed before operating the module. The module is manufactured in a clean room. We recommend only removing the cover in a particle reduced environment.

Guidance on Water Cooling

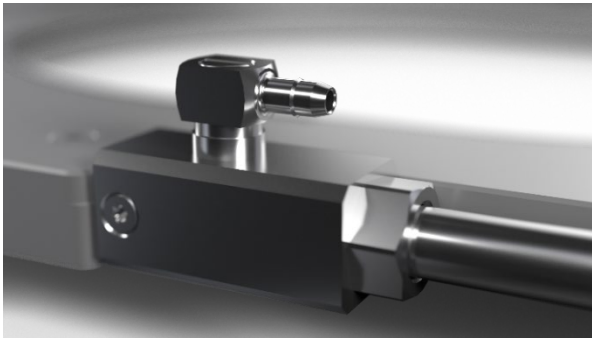

Water cooling of both the base plate and S-bend tube is required for successful operation of the module. The base plate should be cooled with a separate cooling plate while the S-bend tube needs cooling by flow through the S-bend tube itself. Lack of water-cooling will cause catastrophic failure even at low power levels.

Water connection



The module has two built-in barbs that fits to 1/8" (3.2 mm) I.D. of polyurethane or vinyl tubing.

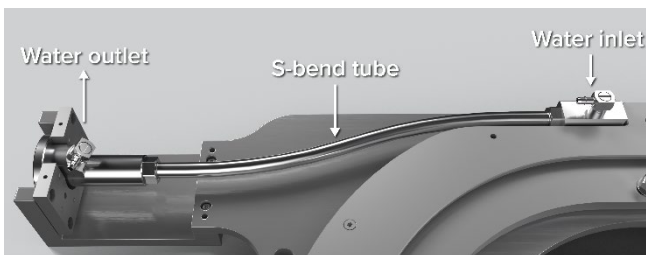

Water flow

The recommended water flow for the mount holding the base plate is 4 ± 2 liter/min. with the fraction of the flow running in the S-bend tube being app. 0.3 liter/min.

Be aware that missing water flow in the S-bend tube will cause damage to the fiber.

Recommended water flow:

- Through the S-bend tube:
0.3 liter/min.
>0.2 liter/min.

<0.5 liter/min.

Flow direction: From base plate to end-cap

- To the cooling plate for the base plate:
 4 ± 2 liter/min.

Water temperature:

- $25^{\circ}\text{C} \pm 5^{\circ}\text{C}$

Chiller system

The mechanical parts of the cooling system in the aeroGAIN-BASE component are made of stainless steel. We recommend stainless steel or plastic components in the waterline and using DI water containing an anti-corrosive additive like Coolflow DTX from Hydratech to avoid corrosion.

To avoid bubble accumulation

After connection of water tubes to the module, bubbles might be trapped in the S-bend tube.

1. Have the water running in the same direction as the amplified signal. Refer to picture below.
2. Create a temporary turbulent flow in the tube by pinching your flexible water tuber 3 times or start and stop the chiller 3 times after attachment to the chiller.

Guidance on the optical system

Spliced seed delivery

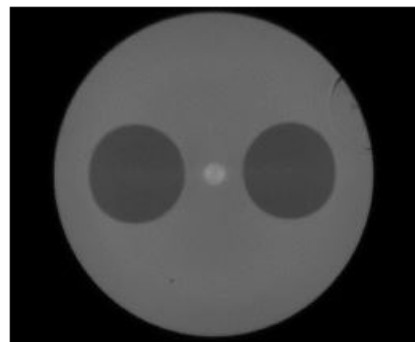

Cross section of input pigtail

Signal coupling is attained by splicing the signal source onto the aeroGAIN-BASE pigtail. Make sure that the splicing is PM aligned! The aeroGAIN-BASE will not function properly if an un-polarized or non-slow axis polarization is coupled.

Though launch of seed by bulk optical coupling into the fiber is possible, we recommend using a spliced seed delivery for stability reasons.

Absence of seed power during operation will cause the fiber to self Q-switch and damage the fiber permanently, leading to catastrophic failure.

Seed power level and bandwidth

Minimum recommended input power level is 500 mW @ 1030-1040 nm for high power operation. Lower input power levels can achieve reliable AGB performance for some low power applications if the signal gain is <20 dB. Higher signal gains can lead to decreased amplifier efficiency, increase of ASE, and risk of q-switches.

We recommend repetition rate ≥ 200 kHz to reduce risk of q-switching and to mitigate gain-shaping of signal pulses. We also recommend seed bandwidth ≥ 1 nm.

Peak power

Fiber amplifier systems are often limited by interaction of (short pulse) high peak power and the nonlinearity of the fused silica fiber medium.

Nonlinearity and the resulting effects are accumulated through the full amplifier chain and must be seen as an interplay between all components of the system, including the seed source.

The aeroGAIN-BASE module was developed for ultrafast lasers in CPA (Chirped pulse amplification) configuration, and the performance of the aeroGAIN Base module will depend on the exact system configuration.

Many typical aeroGAIN BASE CPA configurations for industrial 24/7 applications, are based on peak powers in the 50 to 100 kW range. Operation of the aeroGAIN BASE module above 100 kW are considered extreme operating conditions, and may result in accelerated wear, and cannot be recommended for industrial applications.

Rep rate

We do not have experience with operating the module below 200 kHz. When operating the module below 200 kHz you can get into a regime with complex temporal gain dynamics, that can pot. cause significantly accelerated wear and/or catastrophic failure.

Pulse length

The module is suitable for many different pulse lengths. We recommend staying below 2 ns due to the risk of Stimulated Brillouin Scattering.

Optical isolator

It is highly recommended to have an optical isolator between the input signal source and the aeroGAIN-BASE module.

Pump delivery

We recommend a 976 nm pump with a 200 μm or 100 μm core fiber 0.22 NA fiber delivery. That makes the pump coupling much easier. Other delivery fibers are also possible as the active fiber pump guide has an NA of ≥ 0.55 . We recommend a pump beam waist ≤ 160 μm for optimal coupling into the active fiber.

As the active fiber has a 200 μm diameter pump guide, a pump delivery fiber of 200 μm is a good choice for the bulk optical system.

As the 976 nm absorption peak is relatively narrow, the bandwidth of the pump source should be in the 4 nm region or narrower.

It is important that no significant sidebands are present in the pump spectrum. Pump power in these side bands will be guided all the way through the fiber and end up in the residual pump dump.

It is important to consider either to use a wavelength locked pump or make your own temperature control of the pump to ensure operation around the pump band, also at lower power levels.

Pump coupling

How to do the pump coupling alignment:

Step 1. Only seed present — no pump.

In the direct beam path, we recommend having a lens and dichroic mirror. The lens collimates the AGB signal and couples the pump while the dichroic mirror separates the signal and pump. We suggest sampling a small amount of the AGB signal and imaging it with a second lens onto a CCD camera. The z-position of the collimating lens should be adjusted until the PCF stress elements and core hole structure can be observed on the camera. This focus is close to optimum for a collimated pump.

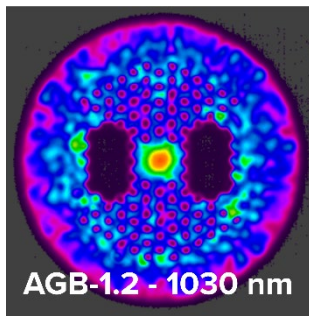

Typical AGB-1.2 output with only seed present

Step 2. Turn on the pump — at low power, < 8 W.

Manipulate the dichroic mirror until you observe amplification of the signal. We propose to use a fast detector for this alignment. Once an amplified signal is detected, the lens position should be fine-tuned for max. signal output.

Step 3. Fine tuning — at low pump power, < 8 W.

A further fine-adjustment of the pump collimating lens distance to the pump delivery fiber and re-alignment of dichroic mirror might improve the pump coupling.

We now increase the pump power and NEVER realign the pump power at higher power levels.

Amplifier fiber

DC-200/40-Pz-Yb

Single mode, polarizing double-clad Ytterbium-fiber with large mode area

DC-200/40-Pz-Yb

- Single mode
- High polarization-extinction-ratio
- Large mode area
- High pump absorption
- High NA circular pump core

The module is based on our DC-200/40-Pz-Yb fiber, the top-of-the-line in flexible ytterbium fibers. It features a mode area of more than 700 μm^2 while keeping single-mode beam quality. Moreover, the fiber is polarizing, resulting in improved polarization-extinction-ratio (PER) compared to normal polarization-maintaining fibers.

The multimode pump light is guided by our proven airclad technology, ensuring low loss, high damage threshold and a large numerical aperture, that relaxes

tolerances on coupling optics and facilitates the use of lower brightness diodes.

Polarization

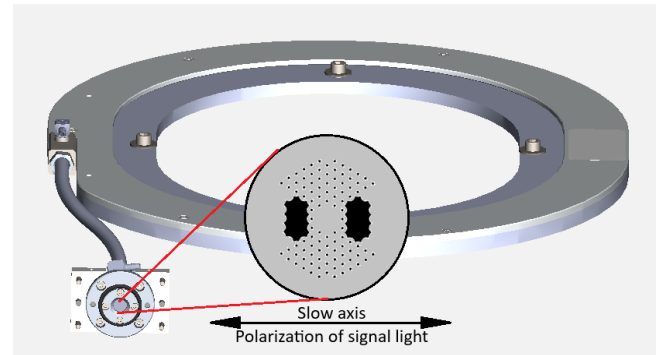

The AGB module should be seeded in the slow axis as the active fiber is polarizing i.e. that light in the fast axis will be lost to the cladding. The AGB output slow axis is orientated in the same plane as the base-plate of the AGB.

The PER depends on the input launch conditions into the fiber, especially the angular alignment between the polarization axis of the light with the slow axis of the fiber.

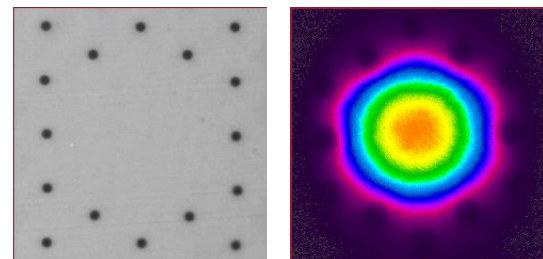

Left: Typical Optical microscope picture of the core region. Right: Typical Near-field measured at 1060 nm.

The single mode advantage

The strictly single-mode operation leads to several advantages compared to standard multimode LMA fibers:

- Better output stability
- Highest possible beam quality
- No coiling-induced mode area compression

Please visit our website for specifications.

Guidance on operation to avoid severe damage

Seed power must always be present

The amplifier fiber must be seeded at ALL TIMES during the launch of pump power to the fiber. In the absence of seed during pumping, the fiber will self Q-switch, become permanently damaged, and possibly damage other system components.

Alignment the pump at low power

We recommend aligning the pump at low power (less than 8 W launched at the end-cap facet). If the beam is misaligned, the pump will propagate outside the pump cladding and can cause significant stress or heat problems. Make sure the x-, y-, and z-manipulators are sufficiently stable to maintain the alignment. Pump coupling steps are described in "Pump coupling" section.

Ensure good coupling efficiency

Before increasing the pump power, a good coupling efficiency must be obtained. The value will depend on how the pump source performs at low power.

As a guideline, a mis-coupled pump, i.e. pump outside of the pump cladding, should not exceed 8 W, preferably much less.

Pump power <100 W

Never launch more than 100W of pump power on the end-cap facet.

Amplified Spontaneous Emission

The end-cap facet of the fiber might be destroyed if ASE (Amplified Spontaneous Emission) lasing occurs. The amount of ASE depends on the total system architecture, and for that reason we can give no strict limitation for the operation with respect to ASE lasing.

Therefore:

1. Keep the amplifier gain < 20 dB

In the event of more gain, the risk of ASE lasing becomes severely pronounced which can cause catastrophic damage.

2. Monitor forward propagating ASE for $G > 17$ dB

It is always a good idea to monitor the forward propagating ASE, especially in the wavelength region from 1020-1050 nm.

For high-gain operations, the risk of ASE lasing becomes more likely, and inspection of the ASE level is required. We recommend monitoring the forward propagating ASE when operating above 17 dB of amplifier gain.

Dimensions & Drawings

For mechanical drawings and 3D model (.STEP) files for module, transport plate, and handling tool, please see the aeroGAIN BASE product page at the [NKT Photonics website](https://www.nktphotonics.com), where download links to relevant files are posted.

Downloads

- ↓ [aeroGAIN BASE 1.2 Datasheet](#)
- ↓ [aeroGAIN BASE 1.2 Handling Instructions](#)
- ↓ [aeroGAIN BASE 1.2 Module \(3d model file\).step](#)
- ↓ [aeroGAIN BASE 1.2 Module with transport plate](#)
- ↓ [aeroGAIN BASE 1.2 Mounting handle \(3d model file\).step](#)
- ↓ [aeroGAIN BASE 1.2 Mounting handles](#)

Removing the module from the tooling plate

The aeroGAIN-BASE module is delivered on a tooling plate (dark part of the photo below). This is to ensure a stress-free environment for the fiber during shipping and storage.

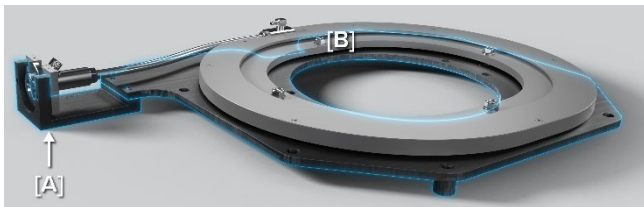

Picture showing an AGB-1.2 module on a dark demo tooling plate for illustration (not a production unit).

Design

To avoid stress from CTE (Coefficient of thermal expansion) mismatch, the AGB module is designed with the S-bend tube “floating” in two O-rings. This, however, allows for damage to the component, if by force, the end-cap housing is pulled away from the fiber spool.

It is important to ensure that the distance between the end-cap housing [A] and fiber spool [B] is not changed when the AGB module is removed from the tooling plate. It is required to use a spacer or handle for this operation.

When removing the aeroGAIN-BASE component from the tooling plate to be integrated into a laser, it is VERY important that the distance between the end-cap housing [A] and the fiber spool [B] is maintained by a spacer or a handle, as shown in the picture below.

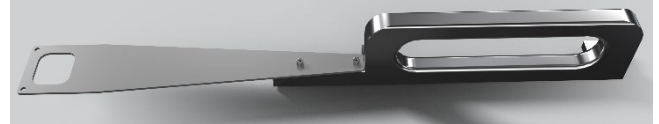

An example of an AGB-1.2 “Mounting handle tool”



Handle positioned on a demo unit

See section “Dimensions and drawings” where design examples are listed, with references to “Mounting handle tool” mechanical drawings and 3D model files available for download.

The end-cap housing and fiber spool have threaded holes that can be used for spacer (handle) attachment.

Failure to maintain this distance might result in severe failure for the component.

For this purpose, the end-cap housing has 2 x M2.5x0.45, depth 8 mm holes [A] and the fiber spool has 3 x M3x0.5, depth 13 mm holes [B].

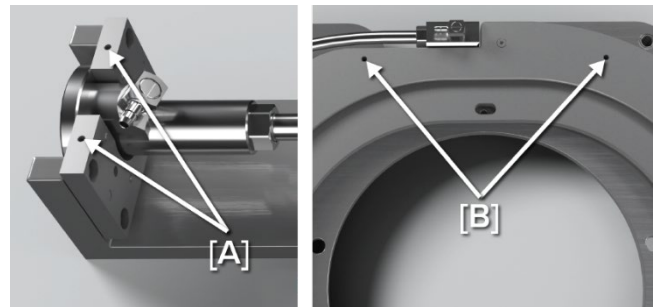

The end-cap housing is mounted to the tooling plate with 4 screws and the fiber spool with 4 other screws.

When these are removed, the module can slide backwards. The module must be removed from the tooling plate U-holder until the pins in the end-cap housing are free from the U-holder.

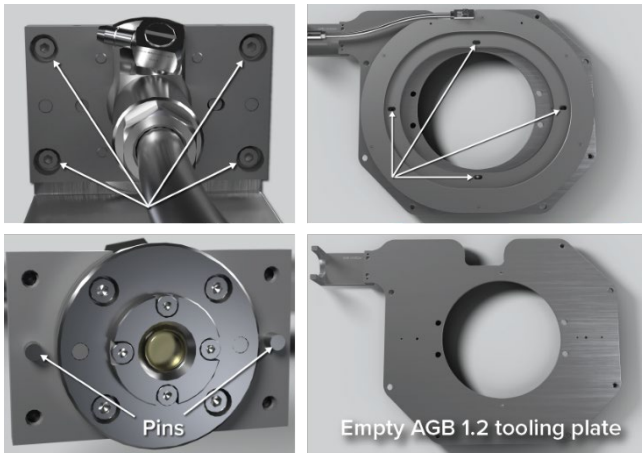

Procedure:

- Attach the AGB “Mounting handle tool”
- Remove the 4 screws from the fiber spool
- Remove the 4 screws from the end-cap housing
- Use the “Mounting handle tool” handle to move the AGB unit from the tooling plate
- Gently slide the AGB module away from the U-holder until the pins leave the U-holder
- The unit can now be lifted away from the tooling plate

Threaded holes for the spacer are required to move the unit from the tooling plate

The 2 holes at the end-cap housing [A] are:
M2.5x0.45, depth: 8.0 mm

The 3 holes at the ring base plate [B] are:
M3.0x0.5, through

IMPORTANT

- DO NOT use the S-bend tube as handle
- DO NOT remove the module from the tooling plate unless the end-cap housing and base-plate are fixed to each other

Visit our website for download of datasheet and specifications.