

# SMA-905 High Power Connector

- High power capability
- Cladding mode stripper
- Sealed, cleanable ends
- Damage resistant polish
- Compatible with SMA hardware
- Angle polish available
- PM fiber alignment

The SMA-905 connector is made to be used with solid core Photonic Crystal Fibers (PCF) at applications requiring high power levels.

The connector has an end which is sealed and polished to an exceptional surface finish, and the sides of the connector features an effective stripping of excess pump light.

The connector is made from precision machined copper to increase thermal conductivity for reliable operation and a high power handling capability.

It is specially optimized for use with high power diode laser pump sources, such as those commonly used to pump active airclad fiber lasers/-amplifiers.

The connector can also be used with Large Mode Area and High NA fibers.

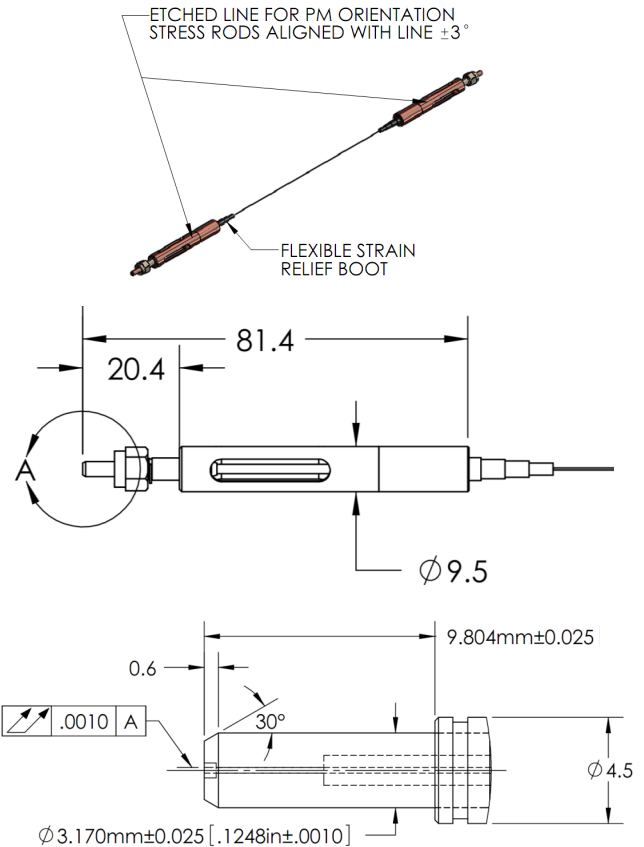

## Temperature behaviour of connector

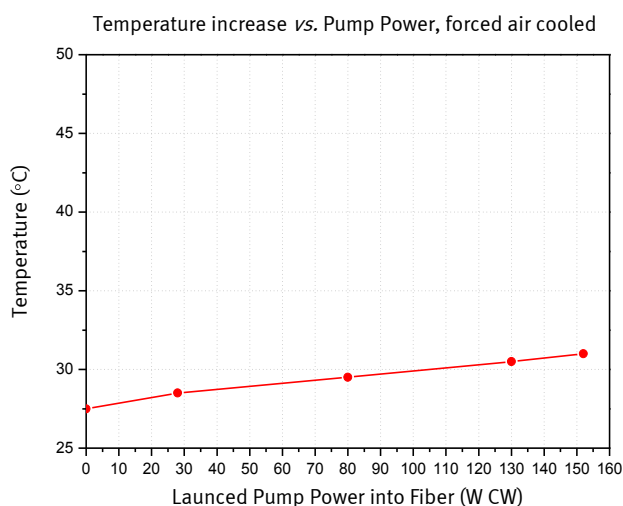

## End sealing and end-caps

As a part of the connectorization process, the fiber is hermetically sealed at the end. This can be done by collapsing the microstructure (traditional sealing) or by splicing on a pure silica end-cap with the same diameter as the fiber itself.

The sealing causes the mode to diverge towards the end facet, resulting in a higher damage threshold of the fiber due to the lower intensity on the facet.

The sealing does not affect the high NA of the pump cladding.

## Custom Options\*

- Angle polishing 0-8°
- fiber sealing length 50-10,000 µm
- Rotational alignment

\* Exact options available depend on the fiber to be connectorized

SMA-905 high-power connector-110816